

2009- Nissan GT-R 3.8L Turbo

Warning: When working on, under, or around any vehicle exercise caution. Please allow the vehicle's exhaust system to cool before removal, as exhaust system temperatures may cause severe burns. If working without a lift, always consult vehicle manual for correct lifting specifications. Always wear safety glasses and ensure a safe work area. Serious injury or death could occur if safety measures are not followed.

Step 1: This Magnaflow system re-uses the factory tips for best aesthetics, remember to remove them for installation later. Begin removing your OEM exhaust system by un-fastening the two bolt flange at the outlet of the catalytic converters. Working front to rear detach all hangers from the rubber isolators. Remove the system from the vehicle. To facilitate easier installation, at this point un-bolt and remove the two rear muffler hanger assemblies from the vehicle.

Step 2: Install your new MAGNAFLOW system by first attaching the Inlet Pipe Assembly to the catalytic converter outlet flange. Locate the hanger to the rubber isolator. At this point (ON THE GROUND) begin assembling the remainder of the system. Loosely assemble the T-Pipe and both Muffler Assemblies with the supplied clamps and fasteners (Fig 1.), at this point also mount the rear hanger assemblies (that were removed previous) to the Muffler Assemblies. Install this complete assembly as one piece by inserting the T-Pipe inlet into the Inlet Pipe Assembly, inserting the hangers into rubber isolators and bolting the muffler hanger assemblies to the car.

Step 3: With all components mounted loosely, adjust the system for overall aesthetics and clearance of frame & bodywork. (MAGNAFLOW recommends at least 1/2" of clearance between the exhaust system and any body panels to prevent heat-related body damage or fire.) At this point re-install the factory tips and center in the fascia opening.

Step 4: Once a final position has been chosen for the new system, evenly tighten all fasteners from front to rear. The supplied band clamps must be VERY tight to properly align the pipes and prevent leaks (Approximately 40ft-lbs). U-bolt clamps should be tightened to approximately 30-35ft-lbs. inspect all fasteners after 25-50 miles of operation and retighten if necessary.

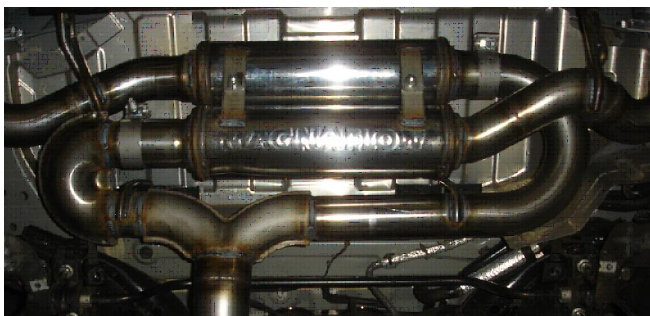
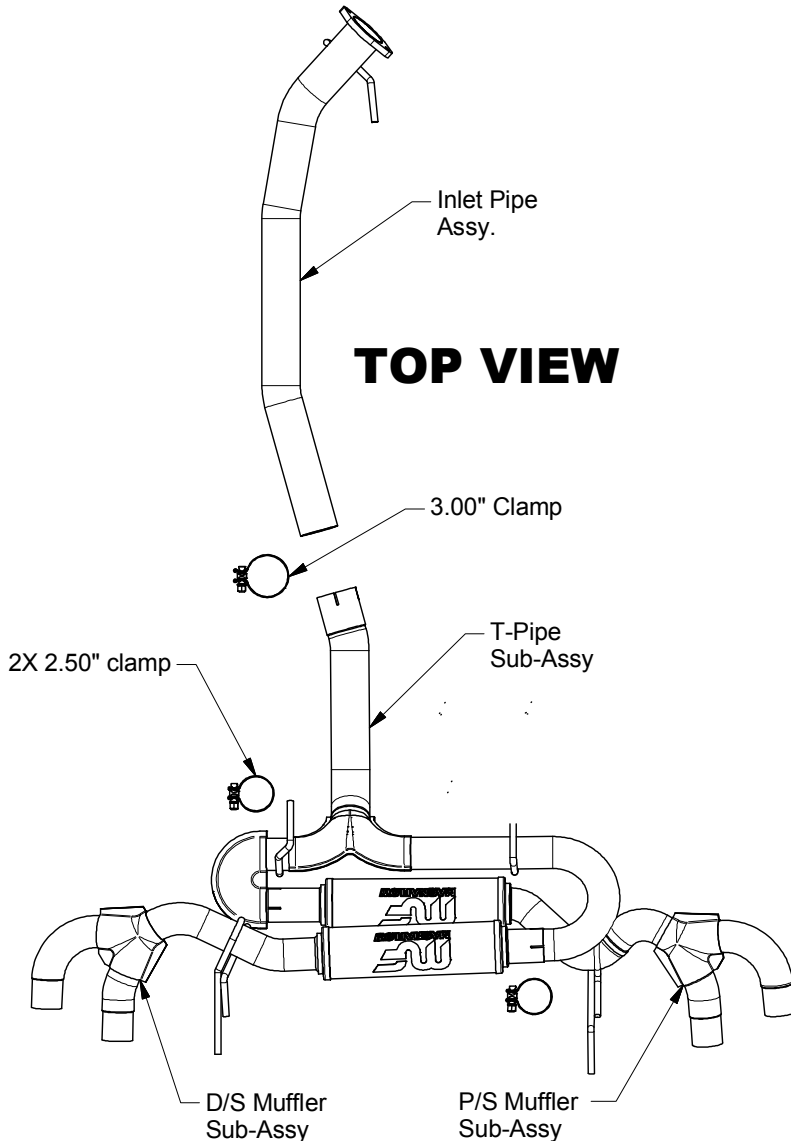

Fig 1. View from bottom

**** Magnaflow Performance Exhaust recommends professional installation on all their products**